



FYJ180

Motore per ascensore

Sospensione : 1:1

Controllo : VVVF

Freno (DZE-9E) : DC110V 1 A

Peso : 430 kg

Portata Max statica : 3500 kg

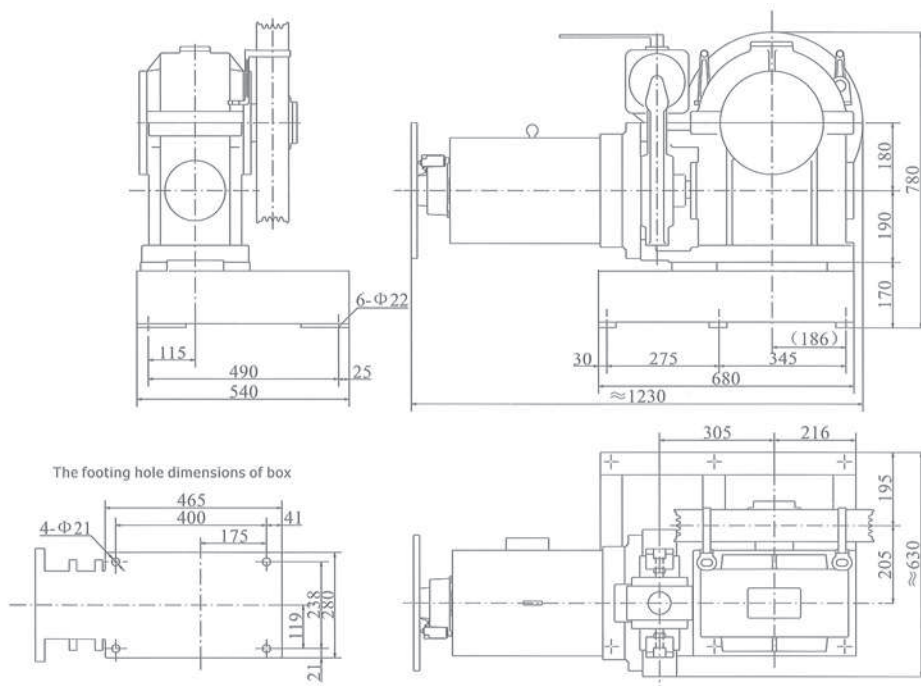

Carico (kg)	Velocità (m/s)	Rapporto	Puleggia ø (mm)	Funi (mm)	Potenza (kW)	Poli
630	0,75	47:1	Ø 480	4X12(Pitch 18)	5,5	4
630	1,0	36:1	Ø 480	4X12(Pitch 18)	6,4	4
630	1,5	47:2	Ø 480	4X12(Pitch 18)	9	4

Nota:
La puleggia a destra e' facoltativa.